

**25450-25454**

## 1. Symbols and warning icons

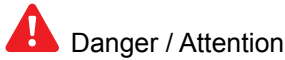

## 2. General warnings

This manual has been prepared for use by qualified personnel and therefore it is not suitable for trainees or “DIYers”. If you are in doubt about the installation and/or maintenance of this product, please contact DOCO International. To avoid severe personal injury, please carefully read and observe all indications and warnings in this manual.

- This manual describes the installation, use and maintenance of the cable break safety device 25450-25454.
- This cable break safety device has been designed in accordance with the latest European standards; however, you should check whether this standard corresponds with your local national standard.
- All measurements are stated in millimetres unless otherwise specified.
- This manual should be kept in a safe place.
- It may be subject to technical changes without any written notice.
- If the cable break safety device has been activated, it should be replaced every time this occurs.

### 2.1 Safety requirements for installation and first use

- This cable break safety device may only be installed by qualified personnel.
- Make sure that the power is switched off and remains switched off while electrical work is carried out!
- Adding or leaving out parts can negatively impact the operation and safety of the door and is therefore strongly discouraged!
- With regard to the installation, all references in this manual to left/right are always taken to mean as viewed from the installation location, i.e. from the inside looking out.
- Never use the sectional door in the event of visible damage to the cable break safety device.
- Secure the installation/maintenance location with safety ribbon to keep others (especially children!) at a distance.
- Maintenance must only be performed by a qualified company and/or qualified personnel.

## 3. Uses

These cable break safety devices can be used on manually-operated, chain-operated and electrically-operated industrial doors. The cable break safety device is suitable for sectional overhead doors with a minimum weight of 30 kg and a maximum weight

of 750 kg. The cable diameter should be a minimum of  $\varnothing 4\text{mm}$  and a maximum of  $\varnothing 6\text{mm}$ . The door must be fitted with 2 lifting cables. A cable break safety device should be installed on each lifting cable. Tracks must be in accordance with Doco specifications. Device is designed to be used with  $\varnothing 46\text{mm}$  roller with a 11mm shaft. The radius of the track curve should be at least 380 mm.

### 3.1 Track specifications

Material: Wnr: 1.0226 / DX51  
 Maximum hardness permitted: 90 Rockwell B  
 Material thickness: 1.5 to 2 mm  
 Stainless steel is not permitted  
 Track type Doco.

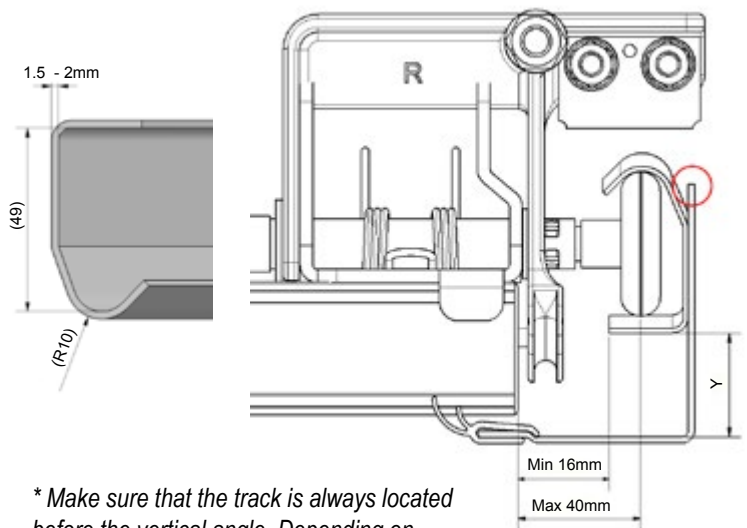

## 4. Fasteners

 The fastener required to install this cable break safety device onto the door panel is not included! It is the responsibility of the installer to make sure that the installation location is strong enough, from an structural point of view, to support the cable break safety device. The installer is also responsible for using the correct fasteners. The self-tapping screw ST 6.3 x 35 (DOCO:14017) is used in the manual. Make sure that the vertical angle track set is stable fixed to the construction.

## 5. Principle of operation

The weight of the door gives tension to the lifting cables that makes the rotating module rotate downwards. The rotating module is then held in fixed position by the two bent sections of the base plate. The door can now operate normally.

When the tension on the cable goes off (because of a cable break), the rotating module then moves upward due to tension of the spring in the device. The knife on

the rotating module will then bite into the track, thereby stopping the falling of the door. In normal working the tension on the cable may never be lower than the tension in the spring of the device.

When using an electric operated door a microswitch (article number: 25446A) needs to be installed on the cable break device. The rotation of the rotating module will cut the power to the motor, preventing the operator to cause damages.



## 6. Installation

This installation manual describes the installation of a right-side cable break safety device. Every door will be installed with one right-side and one left-side cable break safety device.

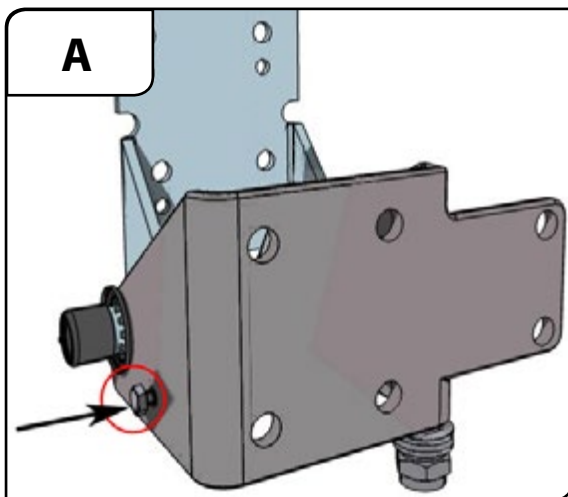

A. Block the rotating module by placing a pin into the hole on its side.

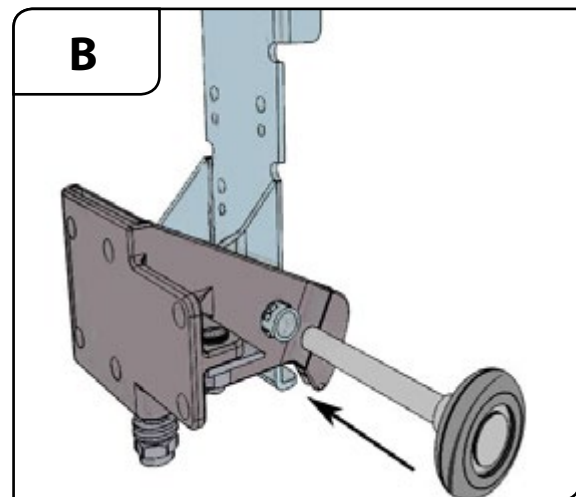

B. Insert a roller into the tube. The black rubber cap has a transportation purpose only. It may be removed when assembling the roller on the device.

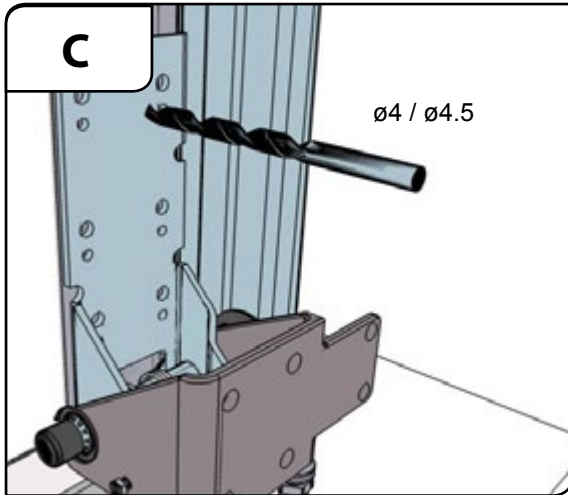

C. Predrill on 8 points.

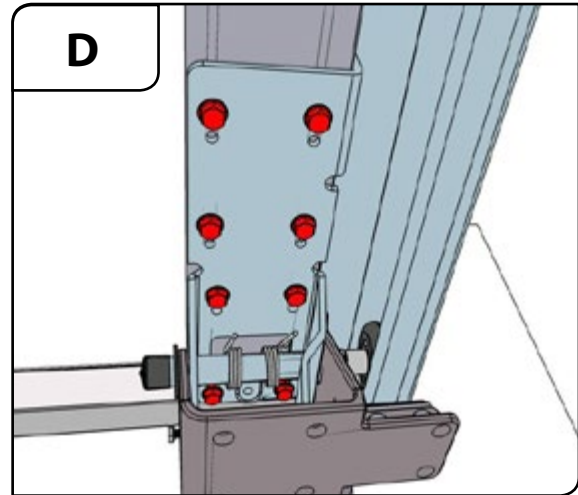

D. Mount the device using 8 x 14017 self tapping screws. Use 6 Nm torque to fix.

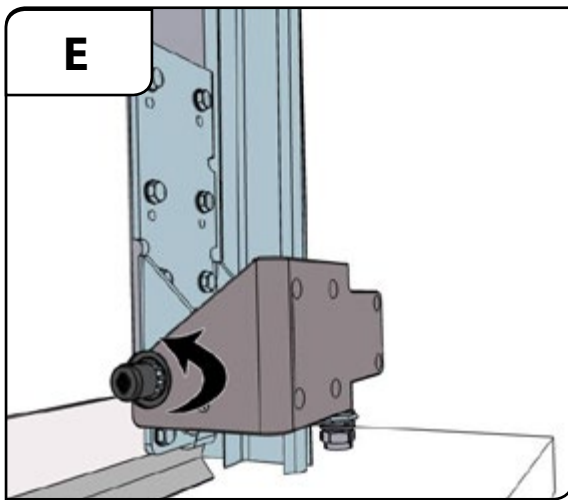

**!** E. While the door is supported and there is no tension in the lifting cables, check if the roller moves freely into the track and also verify, by removing the bolt or nail in the rotating module, if it rotates freely until the blade reaches the track. After checking replace the nail or bolt!

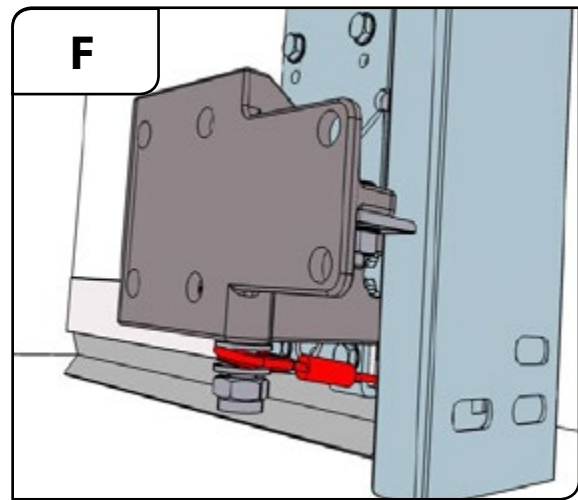

F. Attach the lifting cables on both safety bottom brackets by using the threaded stud and nut supplied. Be sure that the lifting cables follow the groove of the rotating module. Torque to tighten the nut must not be greater than 25Nm.

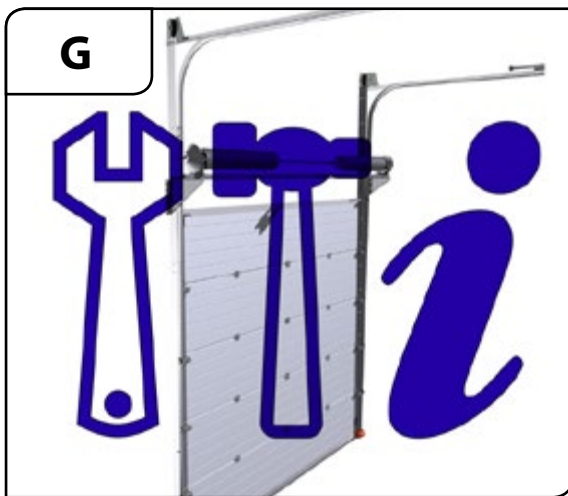

G. Complete the installation of the door and be sure there is tension in the lifting cables.track. After checking remove the pin!

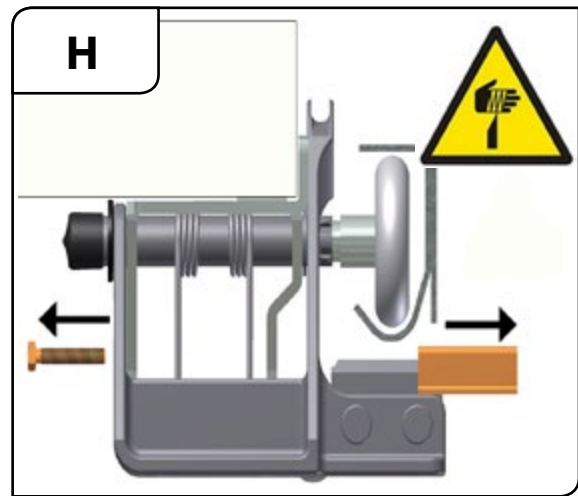

H. Remove the temporary bolt or nail. Remove knife protection strip. The device is now ready to operate. Repeat the installation on the other side.



## 6.1 Installation instructions 25454

For installation of 25454, follow steps A till E. For cable assembly, continue here.

Maximum cable  $\varnothing$ 6mm

Use a cable with a end stud ( art.nb:25115-25116-25117)

Adjust cable tension by untighten the nuts (kw 24mm).  
NOTE: Only release tension.

Continue with point G and H (page4).

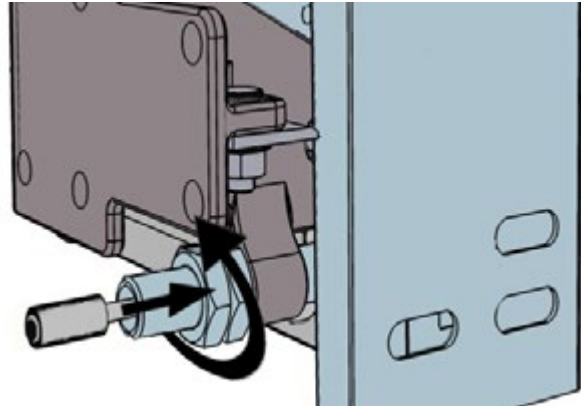

## 7. Installation of Microswitch (25446A)

**!** Required by E-operator (except “Hold to run” operation). The cable break safety device must be fitted with an E-switch. This will turn off the motor in the event of a cable break. Install the switch as shown. This article needs to be ordered separately

Qty	Art.nb	Description
4	14041	M2 x 12 Bolt
4	14042	M2 Nut
2	25445	Microswitch
1	25446R	Microswitch retainer right
1	25446L	Microswitch retainer left
Contents of art.nb. 25446A		

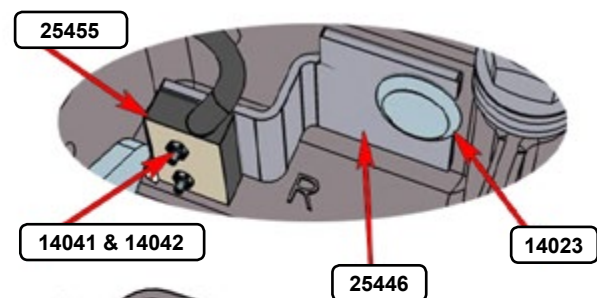
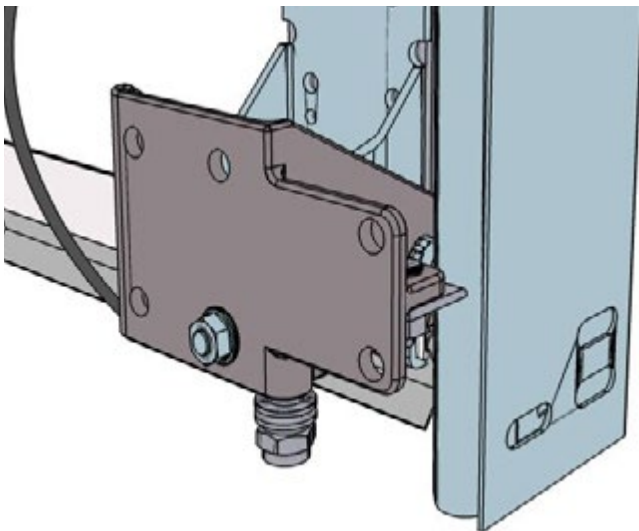

Use bolt and nut 14022 and 14023 to mount 25446 to the rotating bracket.

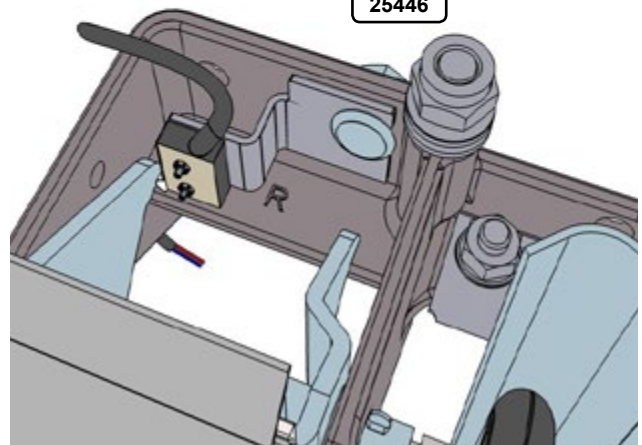

Repeat the installation on the other side. Fixed cable according instruction of the electrical control unit.

## 8. Maintenance

In principle, the cable break safety device should be maintenance-free. However, we do advise you to check for debris and to remove any debris on a regular basis (every 6 months).

## 9. Testing the cable break protection

In accordance with CE regulations, sectional doors should be checked yearly.

The maintenance engineer should check the following:

- 1: Check whether the knives has been damaged. This could mean the knives rubs against the guide track.
- 2: If the knife is damaged, the entire cable break protection unit should be replaced.
- 3: For electrically operated gates (except "Hold to run" operation), check whether the micro switch activates and check the rotation of the module.

## 10. Replacement after a cable break safety device has been activated.

The replacement of cable break safety devices may only be carried out by qualified installation personnel. If, during replacement, the (overhead) door is not in a normal condition, you must ensure that the door blade is secured at all times, in such a way that the door blade cannot move downwards.

- 1: Secure the door blade, for example by using struts.
- 2: Now push the door blade further up, so that the knife separates from the track. Temporarily secure the module with the split pin, in such a way as to jam the module.
- 3: Lock the door. Release the springs to take any tension off the cable.
- 4: Check all parts of the door for damage and replace any parts if necessary. Remove the burr in the rails if this is not to be replaced.
- 5: Replace both of the cable break safety devices and cables in accordance with the installation instructions.

## 11. Certificate number:

This spring break protection carries Prüfbescheinigungs Number TorFV 6/102 tested by TÜV süd. This means that the cable break protection complies with the EU standard, EN 12604 /12605.



EN 13241-1  
TÜV SÜD  
TorFV 6/102

Article: 25450  
25454

Max. door weight:  
7500 N (pair)



## 12. Hole patterns

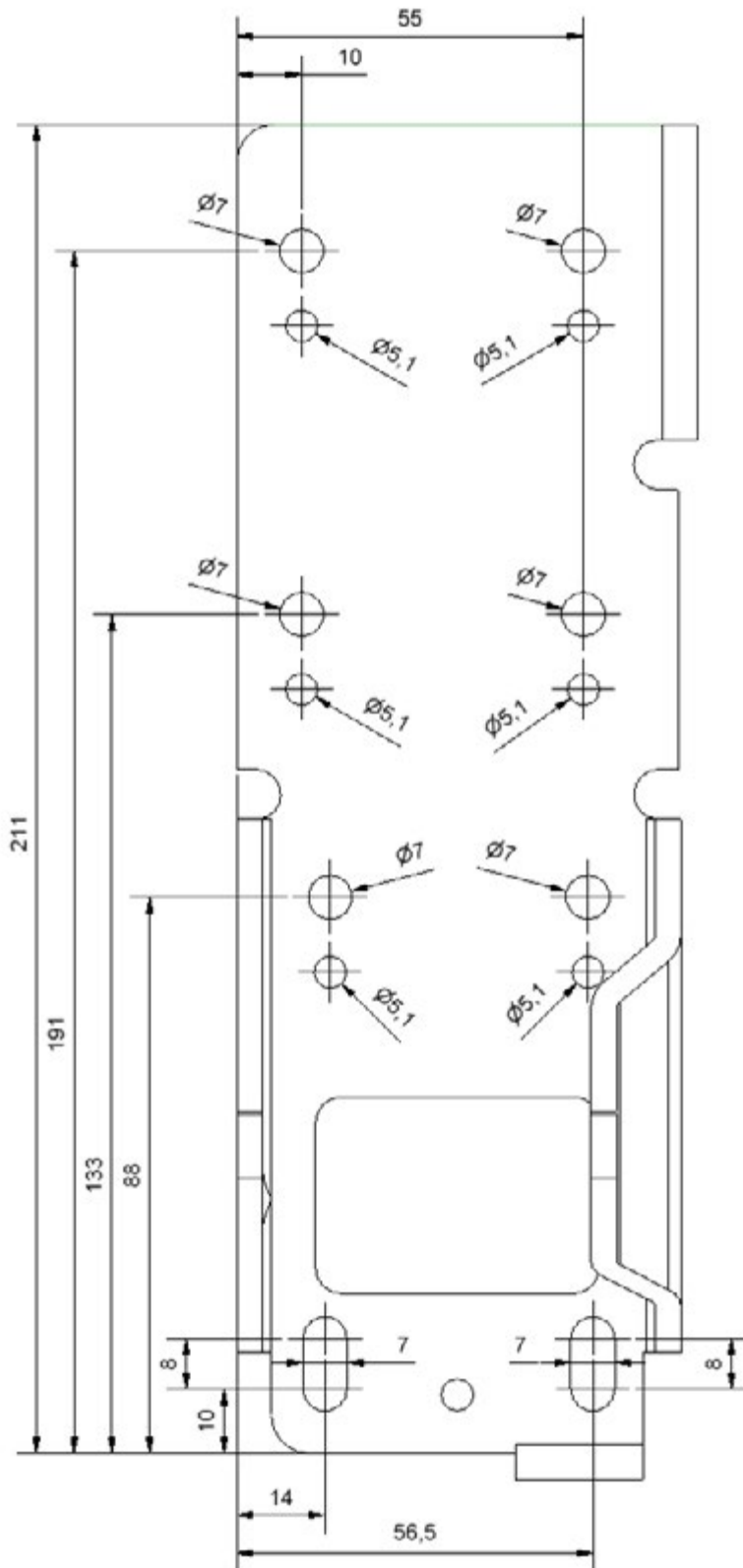

Subsidiaries

**DOCO International B.V.**

Nusterweg 96  
6136 KV Sittard  
The Netherlands  
Phone +31 464200666  
Fax +31 464526894  
info@doco-international.com

**DOCO International  
Central Europe S.R.O.**

Háj 352  
798 12 Kralice na Hané  
Czech Republic  
Phone +420 582360100  
Fax +420 582360300  
info@doco-international.com

**DOCO International Ltd.**

Unit B3 Elvington Industrial Estate  
Elvington  
York  
YO41 4AR  
United Kingdom  
Phone +44 1904607869  
Fax +44 1904607299  
sales@doco-international.co.uk

**DOCO International  
Southern Europe S.L.U.**

Avenida Generalitat 55  
P.I. "Can Met Sidru"  
08530 La Garriga - Barcelona  
Spain  
Phone +34 938612825  
Fax +34 938716592  
ventas@doco-international.com

Sales Offices

**SOMMER Automazioni s.r.l.**

Localita Le Basse 33  
38123 - Trento TN  
Italy  
Phone +39 0461263863  
Fax +39 0461269247  
italia@sommer.eu

**SOMMER Polska Sp.z.o.o.**

Al. Jerozolimskie 439  
05 - 800 Pruszków  
Poland  
Phone +48 222302100  
biuro@sommer-polska.pl

**SOMMER Kft.**

II. Rákóczi Ferenc út 277  
1214 Budapest  
Hungary  
Phone +36 12780261  
Fax +36 12764439  
info@sommerkft.hu

**SOMMER Automation  
& Radio Co., Ltd.**

Fengrao Road 388  
201801 Shanghai, Malu County  
Jiading District, Shanghai  
China  
Phone +86 2169153919  
Fax +86 2169153155  
info@sommer-china.com.cn

